

Homework 1 Solution

- 1.4 14-bit binary: 11_1111_1111_1111
 Decimal: $2^{14}-1 = 16,383_{10}$
 Hexadecimal: $3FFF_{16}$

- 1.13 (a) Convert 27.315 to binary:

	Integer Quotient		Remainder	Coefficient
$27/2 =$	13	+	$\frac{1}{2}$	$a_0 = 1$
$13/2$	6	+	$\frac{1}{2}$	$a_1 = 1$
$6/2$	3	+	0	$a_2 = 0$
$3/2$	1	+	$\frac{1}{2}$	$a_3 = 1$
$\frac{1}{2}$	0	+	$\frac{1}{2}$	$a_4 = 1$

$$27_{10} = 11011_2$$

	Integer		Fraction	Coefficient
$.315 \times 2 =$	0	+	.630	$a_{-1} = 0$
$.630 \times 2 =$	1	+	.26	$a_{-2} = 1$
$.26 \times 2 =$	0	+	.52	$a_{-3} = 0$
$.52 \times 2 =$	1	+	.04	$a_{-4} = 1$

$$.315_{10} \cong .0101_2 = .25 + .0625 = .3125$$

$$27.315 \cong 11011.0101_2$$

- (b) $2/3 \cong .666666667$

	Integer		Fraction	Coefficient
$.6666_6666_67 \times 2 =$	1	+	$.3333_3333_34$	$a_{-1} = 1$
$.333333334 \times 2 =$	0	+	.666666668	$a_{-2} = 0$
$.666666668 \times 2 =$	1	+	.333333336	$a_{-3} = 1$
$.333333336 \times 2 =$	0	+	.666666672	$a_{-4} = 0$
$.666666672 \times 2 =$	1	+	.333333344	$a_{-5} = 1$
$.333333344 \times 2 =$	0	+	.666666688	$a_{-6} = 0$
$.666666688 \times 2 =$	1	+	.333333376	$a_{-7} = 1$
$.333333376 \times 2 =$	0	+	.666666752	$a_{-8} = 0$

$$.666666667_{10} \cong .10101010_2 = .5 + .125 + .0313 + .0078 = .6641_{10}$$

$$.10101010_2 = .1010_1010_2 = .AA_{16} = 10/16 + 10/256 = .6641_{10} \text{ (Same as (b))}.$$

1.20 +49 → 0_110001 (Needs leading zero indicate + value); +29 → 0_011101 (Leading 0 indicates + value)
 -49 → 1_001111; -29 → 1_100011

(a) (+29) + (-49) = 0_011101 + 1_001111 = 1_101100 (1 indicates negative value.)
 Magnitude = 0_010100; Result (+29) + (-49) = -20

(b) (-29) + (+49) = 1_100011 + 0_110001 = 0_010100 (0 indicates positive value)
 (-29) + (+49) = +20

(c) Must increase word size by 1 (sign extension) to accomodate overflow of values:
 (-29) + (-49) = 11_100011 + 11_001111 = 10_110010 (1 indicates negative result)
 Magnitude: 1_001110 = 78₁₀
 Result: (-29) + (-49) = -78

1.22 8,723
 BCD: 1000_0111_0010_0011
 ASCII: 0_011_1000_011_0111_011_0010_011_0001

You don't have to worry about the answer ASCII code. I'll take care it.

1.25 (a) 5,137₁₀ BCD: 0101_0011_0111
 (b) Excess-3: 1000_0100_0110_1010
 (c) 2421: 1011_0001_0011_0111
 (d) 6311: 0111_0001_0100_1001

1.35 (a)

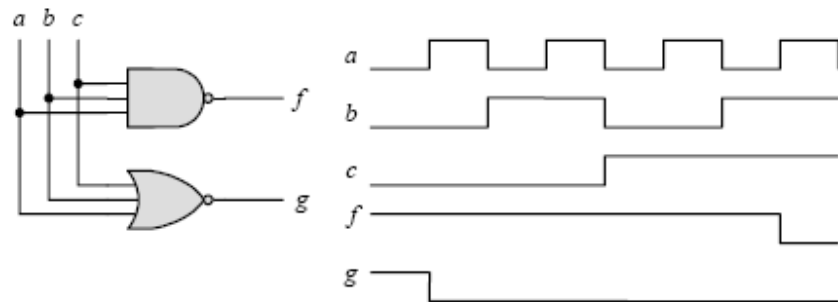

1.36

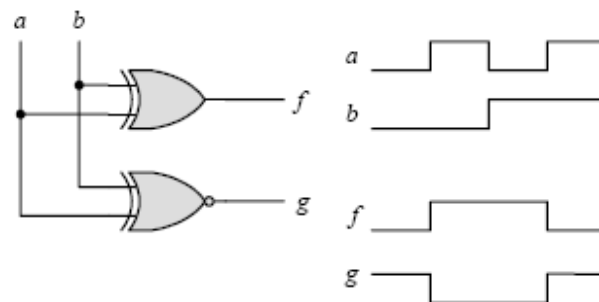

- 2.3 (a) $ABC + A'B + ABC' = AB + A'B = B$
 (b) $(x + y)'(x' + y') = x'y'(x' + y') = x'y'$
 (c) $(BC' + A'D)(AB' + CD') = BC'AB' + BC'CD' + A'DAB' + A'DCD' = 0$

- 2.9 (a) $F' = (xy' + x'y)' = (xy')'(x'y)' = (x' + y)(x + y') = xy + x'y'$
 (b) $F' = [(x' + y + z')(x + y')(x + z)]' = (x' + y + z')' + (x + y')' + (x + z)'$
 $= xy'z + x'y + x'z'$

2.13 (a)

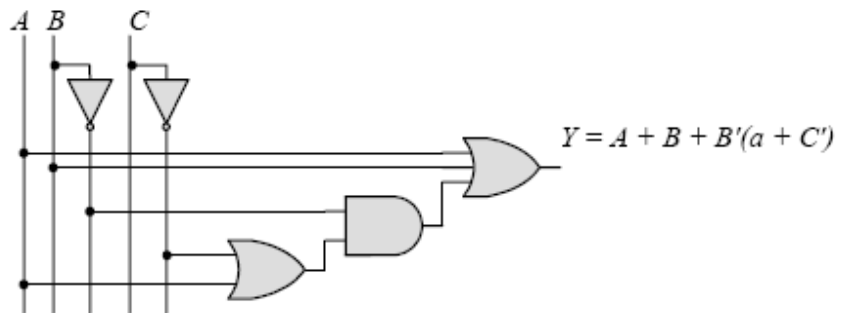

(b)

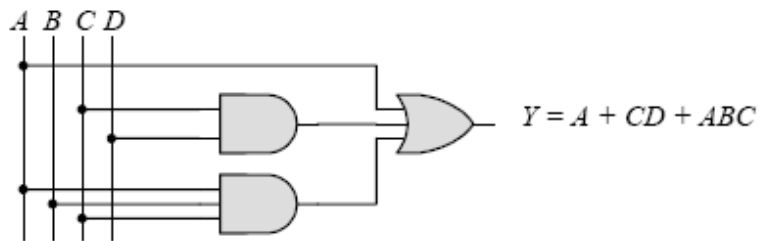

(c)

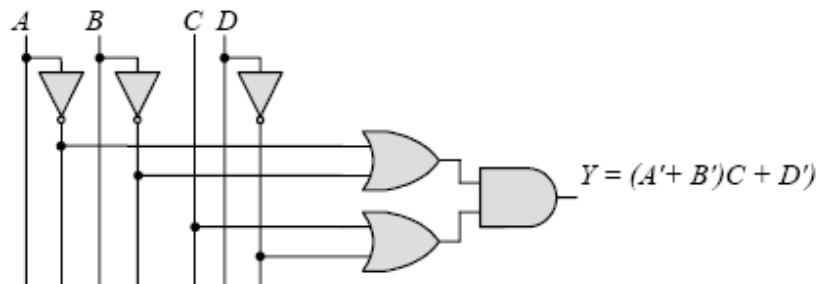

2.18 (a)

wx y z	F	$F = xy'z + x'y'z + w'xy + wx'y + wxy$ $F = \Sigma(1, 5, 6, 7, 9, 10, 11, 13, 14, 15)$
00 0 0	0	
00 0 1	1	
00 1 0	0	
00 1 1	0	
01 0 0	0	
01 0 1	1	
01 1 0	1	
01 1 1	1	
10 0 0	0	
10 0 1	1	
10 1 0	1	
10 1 1	1	
11 0 0	0	
11 0 1	1	
11 1 0	1	
11 1 1	1	

(b) $F = xy'z + x'y'z + w'xy + wx'y + wxy = y'z + xy + wy = y'z + y(w + x)$

(c) $F = y'z + yw + yx = \Sigma(1, 5, 9, 13, 10, 11, 13, 15, 6, 7, 14, 15)$
 $= \Sigma(1, 5, 6, 7, 9, 10, 11, 13, 14, 15)$

2.24 $x \oplus y = x'y + xy'$ and $(x \oplus y)' = (x + y')(x' + y)$

Dual of $x'y + xy' = (x' + y)(x + y') = (x \oplus y)'$

2.28 (a) $y = a(bcd)'e = a(b' + c' + d')e$

$$y = a(b' + c' + d')e = ab'e + ac'e + ad'e = \Sigma(17, 19, 21, 23, 25, 27, 29)$$

a bcde	y	a bcde	y
0 0000	0	1 0000	0
0 0001	0	1 0001	1
0 0010	0	1 0010	0
0 0011	0	1 0011	1
0 0100	0	1 0100	0
0 0101	0	1 0101	1
0 0110	0	1 0110	0
0 0111	0	1 0111	1
	0		0
0 1000	0	1 1000	0
0 1001	0	1 1001	1
0 1010	0	1 1010	0
0 1011	0	1 1011	1
0 1100	0	1 1100	0
0 1101	0	1 1101	1
0 1110	0	1 1110	0
0 1111	0	1 1111	0

3.7

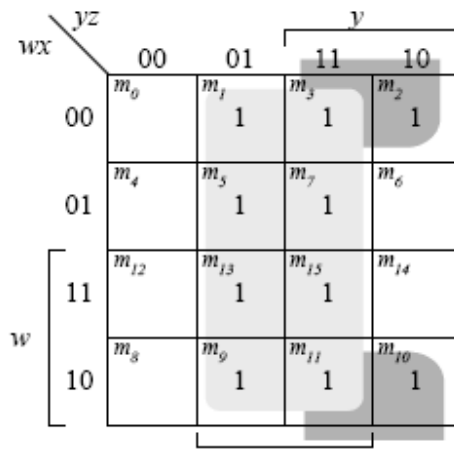

(a) $F = z + x'y$

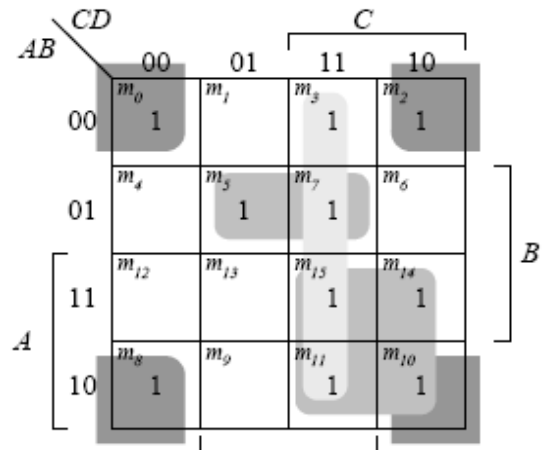

(c) $F = B'D' + AC + A'BD + CD$ (or

3.10

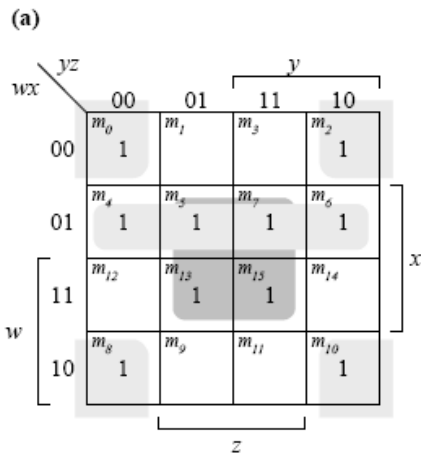

Essential: $xz, w'x, x'z'$
 $F = xz + w'x + x'z'$

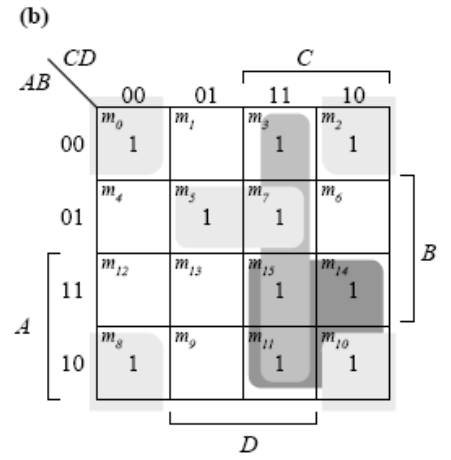

Essential: $AC, B'D', CD, A'BD$
 $F = AC + B'D' + CD + A'BD$

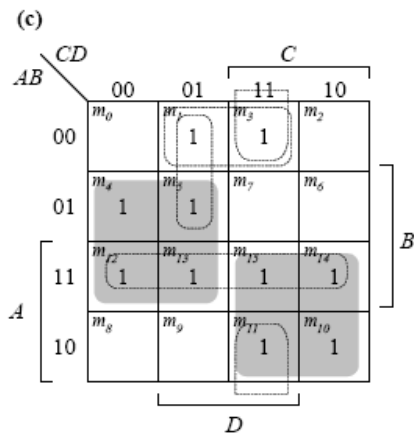

Essential: BC', AC
Non-essential: $AB, A'B'D, B'CD, A'C'D$
 $F = BC' + AC + A'B'D$

3.16 (a)

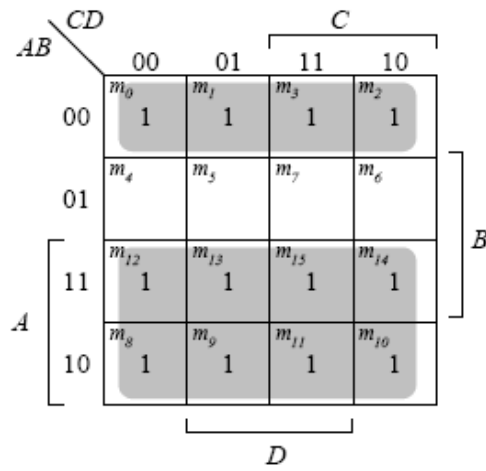

$$F = A + A'B'$$

$$F = (A'(A'B'))'$$

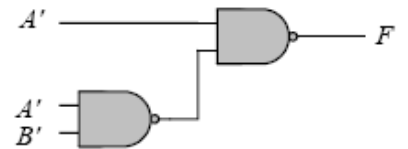

(b)

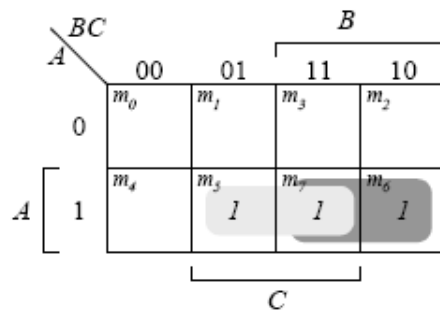

$$F = AC + AB$$

$$F = ((AC)'(AB)')'$$

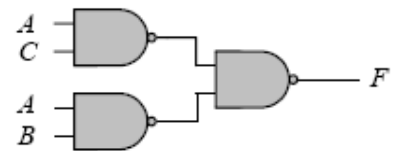

3.20

Multi-level NOR:

$$F = (AB' + CD'E) + BC(A + B)$$

$$F' = [(AB' + CD'E) + BC(A + B)]'$$

$$F' = [[(AB' + CD'E)' + E]' + [(BC)' + (A + B)]']'$$

$$F' = [[((A' + B)' + (C' + D)') + E]' + [(B' + C)' + (A + B)]']'$$

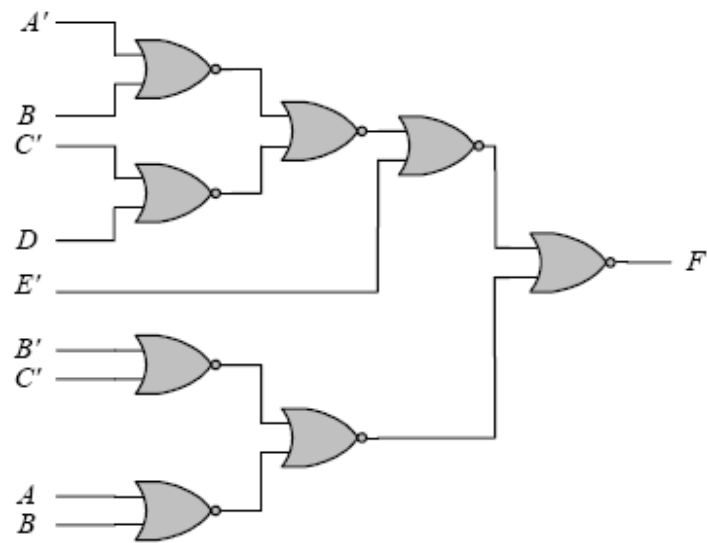

Multi-level NAND:

$$F = (AB' + CD')E + BC(A + B)$$

$$F' = [(AB' + CD')E]' [BC(A + B)]'$$

$$F' = [((AB')'(CD')')'E]' [BC(A'B)']'$$

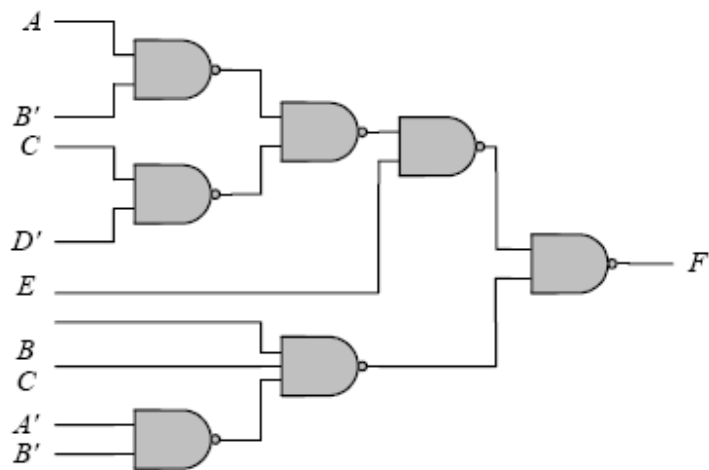

3.26

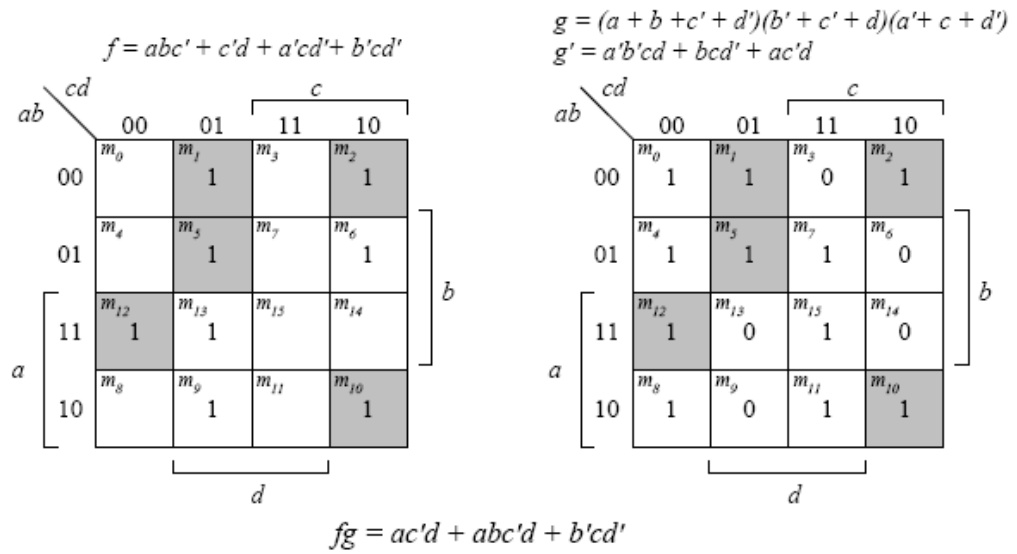

3.29

$$D = A \oplus B \oplus C$$

$$E = A'BC + AB'C = (A \oplus B)C$$

$$F = ABC' + (A' + B')C = ABC' + (AB)'C = (AB) \oplus C$$

$$G = ABC$$

