

Data Link Protocols

ผศ.ดร. อนันต์ พลเพิ่ม
 Asst.Prof. Anan Phonphoem, Ph.D.
anan@cpe.ku.ac.th
<http://www.cpe.ku.ac.th/~anan>
 Computer Engineering Department
 Kasetsart University, Bangkok, Thailand

Data Link Protocols

Asynchronous Protocols

- Xmodem
- Ymodem
- Zmodem
- BLAST
- Kermit

Synchronous Protocols

- Character-oriented
- Bit-oriented

Asynchronous Protocols

- Long, long...time ago
- Not complex and easy to implement
- Slow
- Required start/stop bit and space
- Now mainly used in modem
- → Replaced by high speed synchronous

3 of 53

XMODEM frame

Each character contains start and stop bits (dark portion of the box). Characters are separated from each other by gaps. The header consists of two bytes: sequence number and its one's complement.

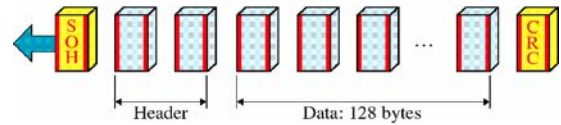

Half-duplex, stop-and-wait ARQ protocol

4 of 53

Data Link Protocols

Asynchronous Protocols

- Xmodem
- Ymodem
- Zmodem
- BLAST
- Kermit

Synchronous Protocols

- Character-oriented (Byte-oriented)
- Bit-oriented
- BSC

Synchronous Protocols

- Character-oriented protocol
 - Based on one byte (8-bit)
 - Use ASCII for control character
 - Not efficient → seldom used
- Bit-oriented protocol
 - Based on individual bits
 - One or multiple bits for control
 - More efficient

6 of 53

IBM's Binary Synchronous Communication (BSC)

- Character-oriented protocol
- Half-duplex, stop-and-wait ARQ
- 2 frame types
 - Data frame (data transmission)
 - Control frame (connect/disconnect and flow/error control)

7 of 53

A simple BSC data frame

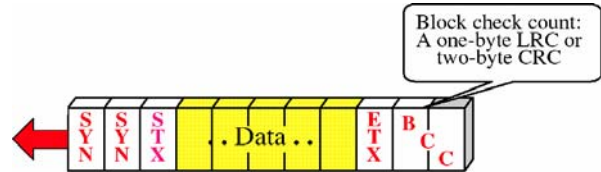

SYN = Synchronous idle = 0010110
 STX = Start of text = 0000010
 ETX = End of text = 0000011

8 of 53

A BSC frame with a header



- Header Fields:
- address (sender/receiver)
 - #frame identifier (0/1 for stop-and-wait ARQ)

9 of 53

A multiblock frame

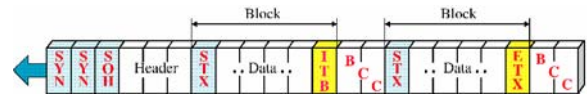

ITB = Intermediate text block

10 of 53

Multiframe transmission

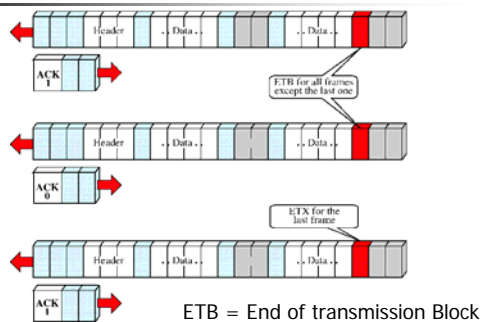

11 of 53

Control frame

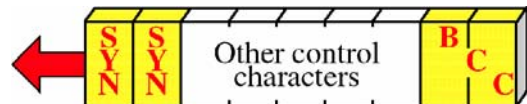

- Note:** Control Frame is used to send command
- * Establish connection
 - * Maintaining flow & error control
 - * terminating connection

12 of 53

Control frames

Connection establishment

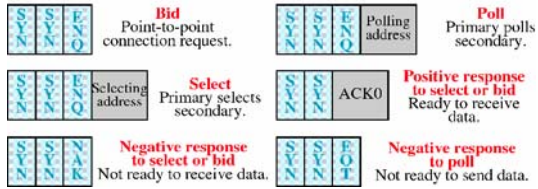

13 of 53

Control frames

Flow and error control

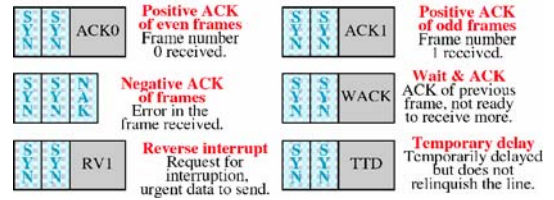

14 of 53

Control frames

Connection termination



15 of 53

Data Transparency

- BSC is designed for text message
- Now, non-text message (graphics,...)
- Problem?
 - BSC control character problem
- **Data transparency**: should be able to send any data

16 of 53

Byte stuffing

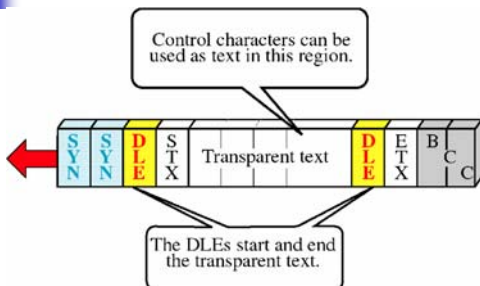

17 of 53

Data Link Protocols

Asynchronous Protocols

- Xmodem
- Ymodem
- Zmodem
- BLAST
- Kermit

Synchronous Protocols

Character-oriented (Byte-oriented)

- BSC

Bit-oriented

18 of 53

Bit-oriented protocol

- Represent more information into shorter frame
- Avoid the transparency problems

19 of 53

Bit-oriented Protocols

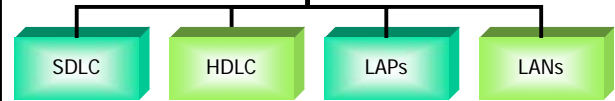

SDLC: Synchronous data link control – IBM
HDLC: High-level data link control – ISO
LAPs : Link access procedure

HDLC

- Support half/full – duplex over point-to-point and multipoint links
- HDLC system characterization
 - Station types
 - Configurations
 - Communication modes
- Frames

21 of 53

HDLC station types

- Primary station
 - The station that controls the medium by sending “command”
- Secondary station
 - The station that “response” to the primary station
- Combined station
 - The station that can both command and response

22 of 53

HDLC configurations

- The relationship of hardware devices on a link
- 3 configurations of all stations (primary/secondary/combined)
 - Unbalanced
 - Symmetrical
 - Balanced

23 of 53

HDLC Configurations: Unbalanced (master/slave)

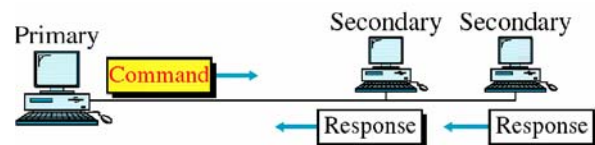

24 of 53

HDLC Configurations: Symmetrical

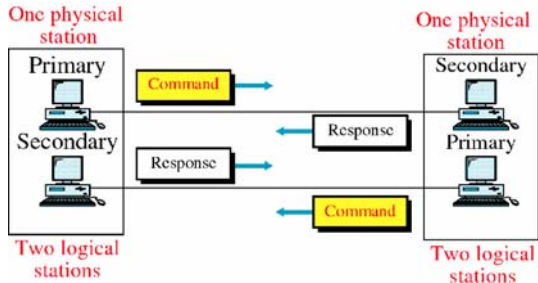

25 of 53

HDLC Configurations: Balanced

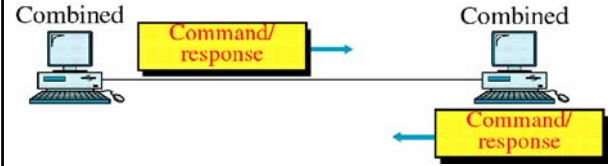

26 of 53

HDLC communication modes

Mode : describe "Who controls the link"

	NRM	ARM	ABM
Station type	Primary & secondary	Primary & secondary	Combined
Initiator	Primary	Either	Any

NRM: Normal response mode (master/slave)

ARM: Asynchronous response mode

(secondary can initiate if idle, all transmissions are made to primary station)

ABM: Asynchronous balanced mode (point-to-point equal)

27 of 53

HDLC frame

- 3 frame types
 - Information frame (I-frame)
 - Supervisory frame (S-frame)
For ACK, Flow/Error controls
 - Unnumbered frame (U-frame)
For Mode setting, Initialize, Disconnect

28 of 53

HDLC Frame

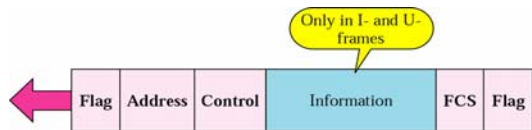

29 of 53

HDLC Frame

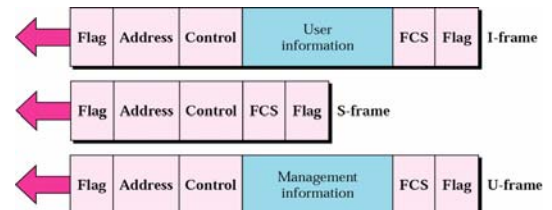

30 of 53

HDLC Frame: Flag field

The flag is 8 bits of a fixed pattern.

01111110

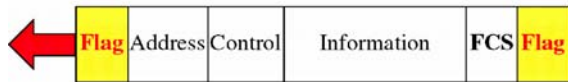

31 of 53

Bit Stuffing

- How to differentiate data and flag?
- Adding one extra 0 whenever there are five consecutive 1s in the data

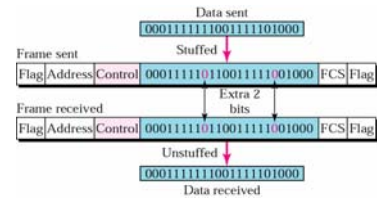

32 of 53

HDLC: Bit stuffing

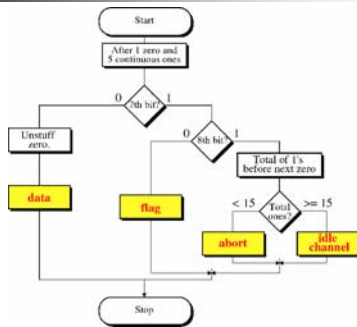

33 of 53

HDLC frame: Address field

- Primary station creates a frame → destination address
- Secondary station creates a frame → source address
- Can be one byte or more

34 of 53

HDLC Frame: Address field

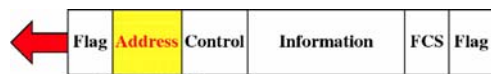

The address is one byte or a multiple of bytes.

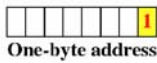

One-byte address



Multi-byte address

35 of 53

HDLC Frame: Control field

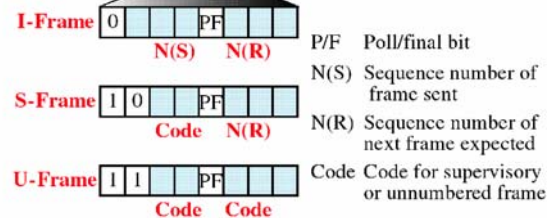

36 of 53

HDLC frame: Poll / Final

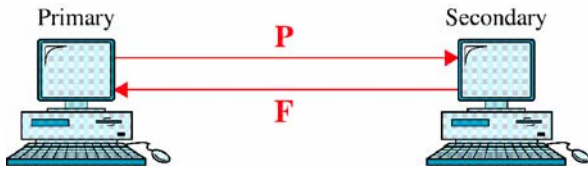

37 of 53

HDLC Frame: Information field

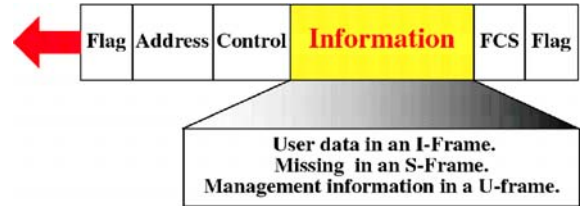

38 of 53

HDLC Frame: FCS field

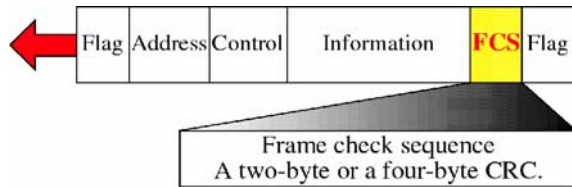

FCS: Frame check sequence

39 of 53

HDLC: S-Frame

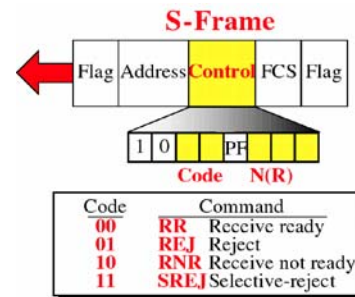

40 of 53

HDLC: Use of P/F field

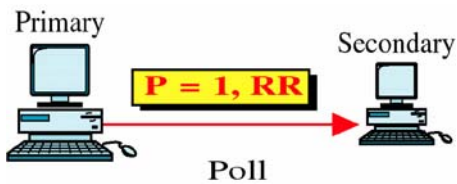

41 of 53

HDLC: Use of P/F field

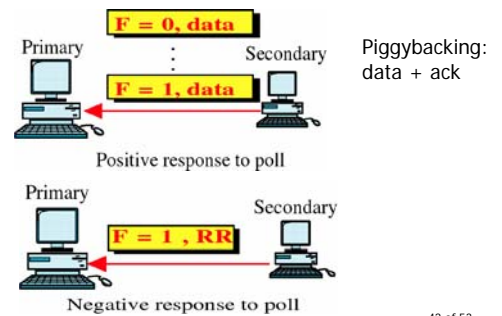

42 of 53

HDLC: Use of P/F field



43 of 53

HDLC: Use of P/F field

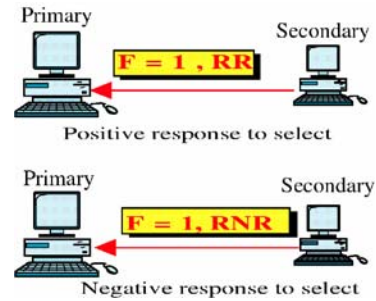

44 of 53

HDLC: S-Frame Acknowledgement

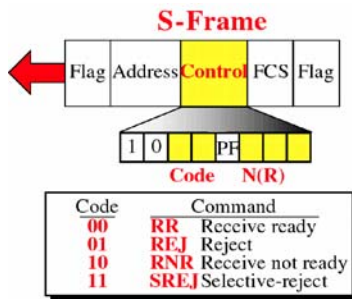

45 of 53

HDLC: S-Frame Positive Acknowledgement

- RR
 - Receiver sends "Positive Ack" (no data to send)
 - N(R) = seq of next frame
- RNR
 - Receiver sends "Positive Ack"
 - N(R) = seq of next frame
 - Receiver tells sender that sender cannot send any frame until 'RR' frame is received

46 of 53

HDLC: S-Frame Negative Acknowledgement

- Reject (REJ)
 - Go-back-n ARQ
 - N(R) = # of damage frame (and follow)
- Selective-Reject (SREJ)
 - N(R) = # of damage frame

47 of 53

HDLC: U-Frame control field

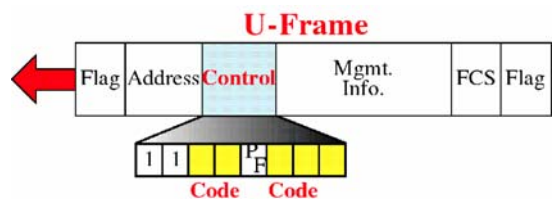

For session management and control information

48 of 53

HDLC: U-Frame control field

Code	Command	Response
00 001	SNRM	
11 011	SNRME	
11 000	SARM	DM
11 010	SARME	
11 100	SABM	
11 110	SABME	
00 000	UI	UI
00 110		UA
00 010	DISC	RD
10 000	SIM	RIM
00 100	UP	
11 001	RSET	
11 101	XID	XID
10 001		FRMR

49 of 53

HDLC: Polling example

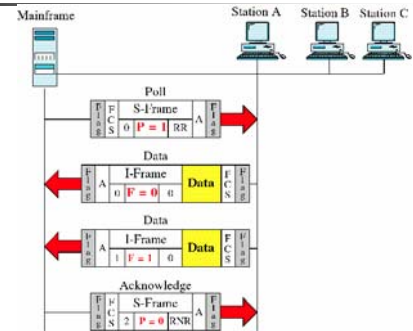

50 of 53

HDLC: Selecting example

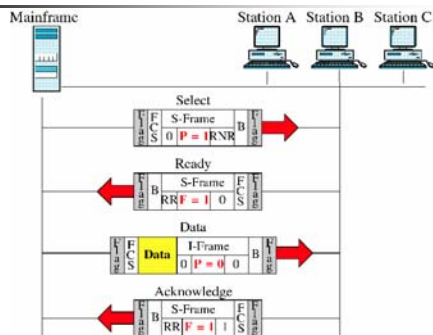

51 of 53

HDLC: Peer-to-peer example

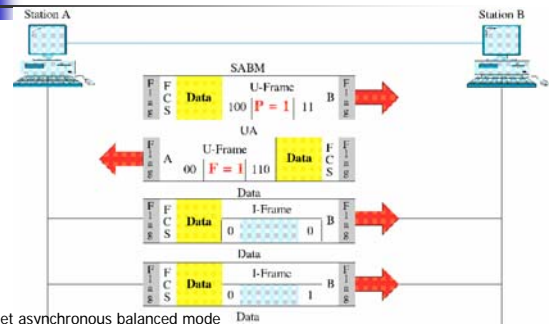

SABM: Set asynchronous balanced mode
UA: Unnumbered ack

52 of 53

HDLC: Peer-to-peer example

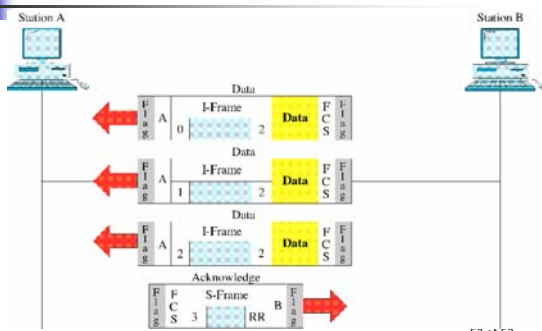

53 of 53